

**J-9 SOFFIT DETAIL**  
3"-1'-0"

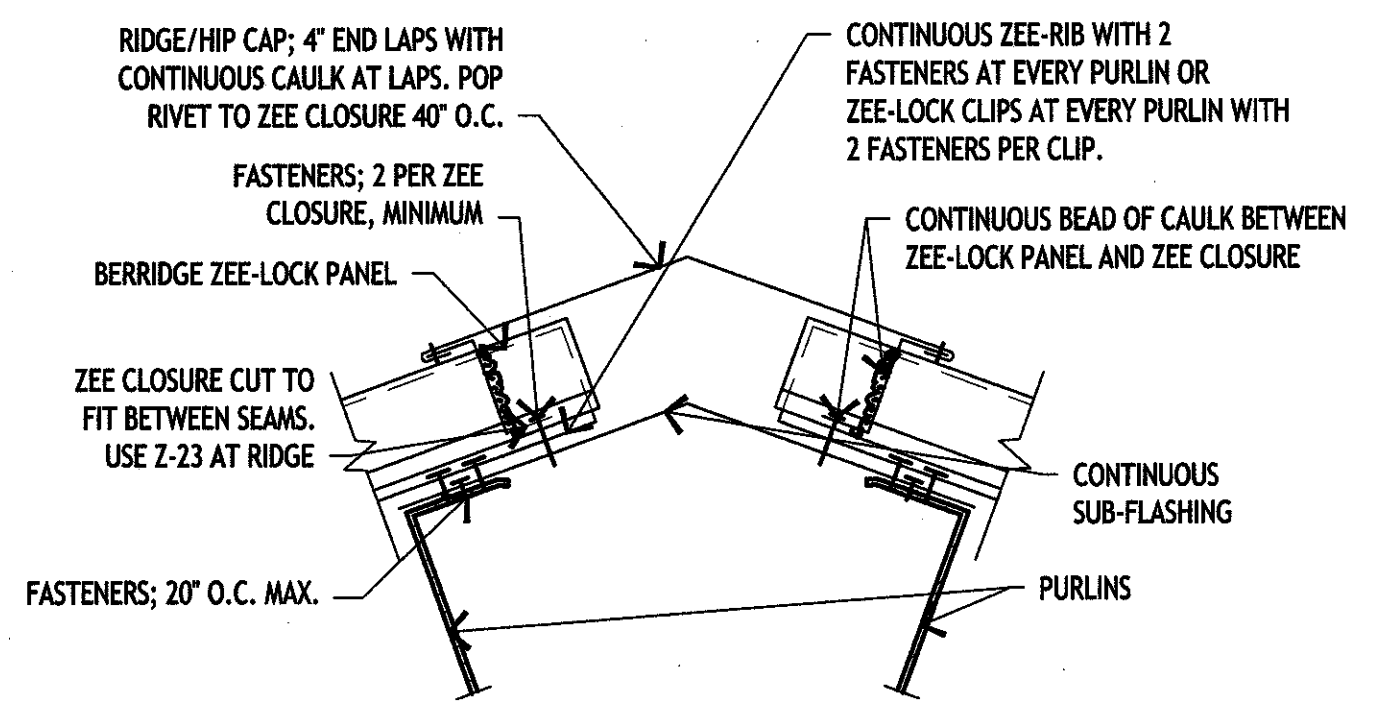

**J-13 RIDGE DETAIL**  
3"-1'-0"

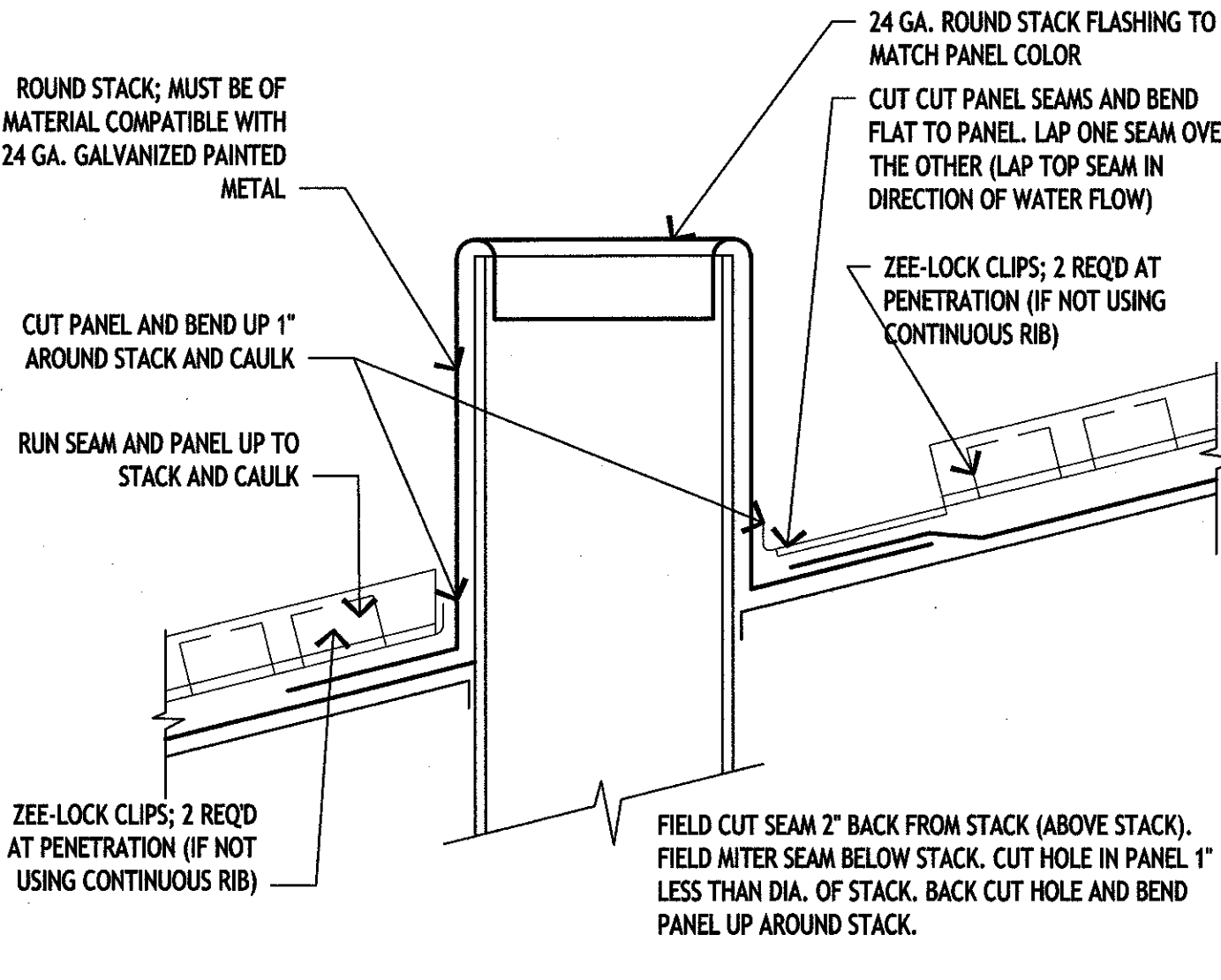

**E-9 ROOF PENETRATION DETAIL**  
3"-1'-0" @ STANDING SEAM

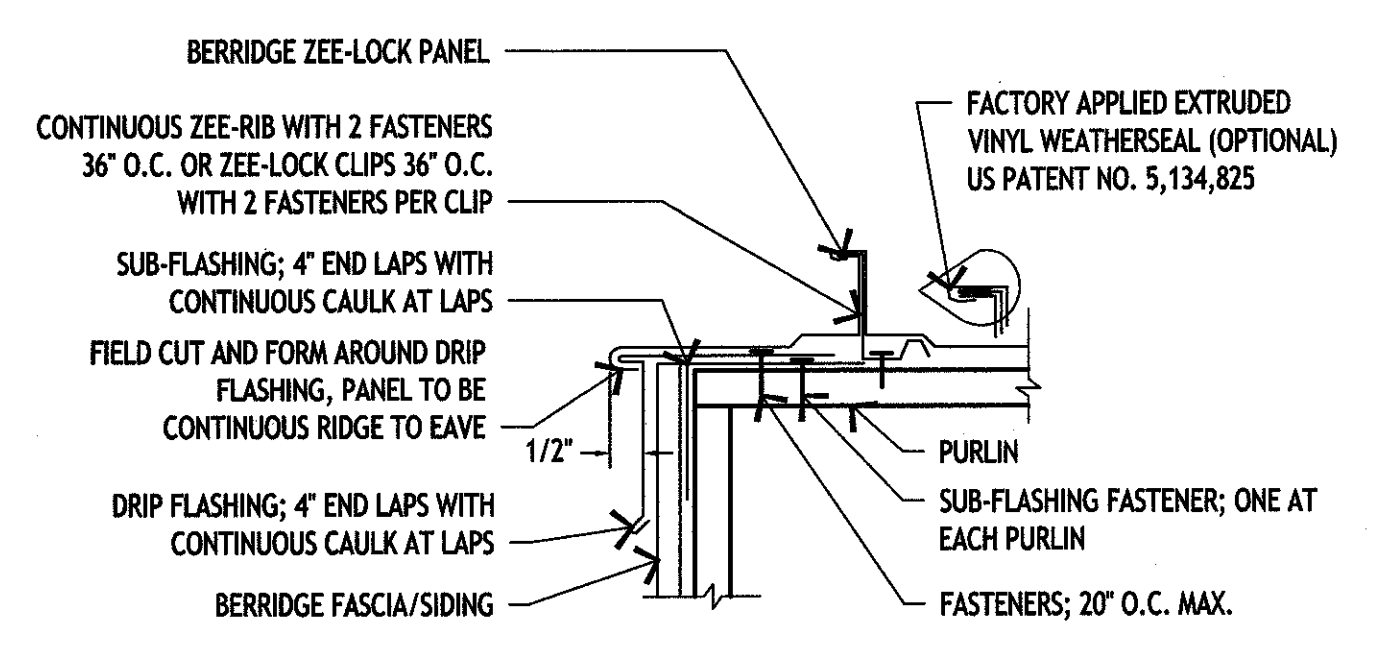

**E-13 EAVE DETAIL**  
3"-1'-0"

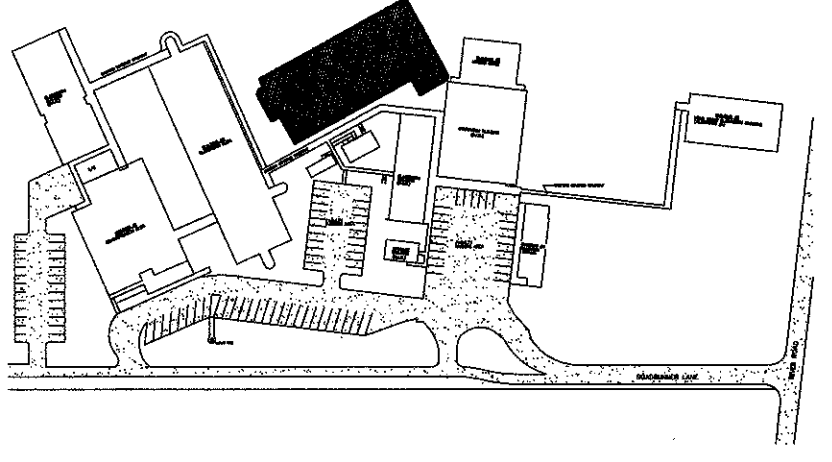

KEY PLAN

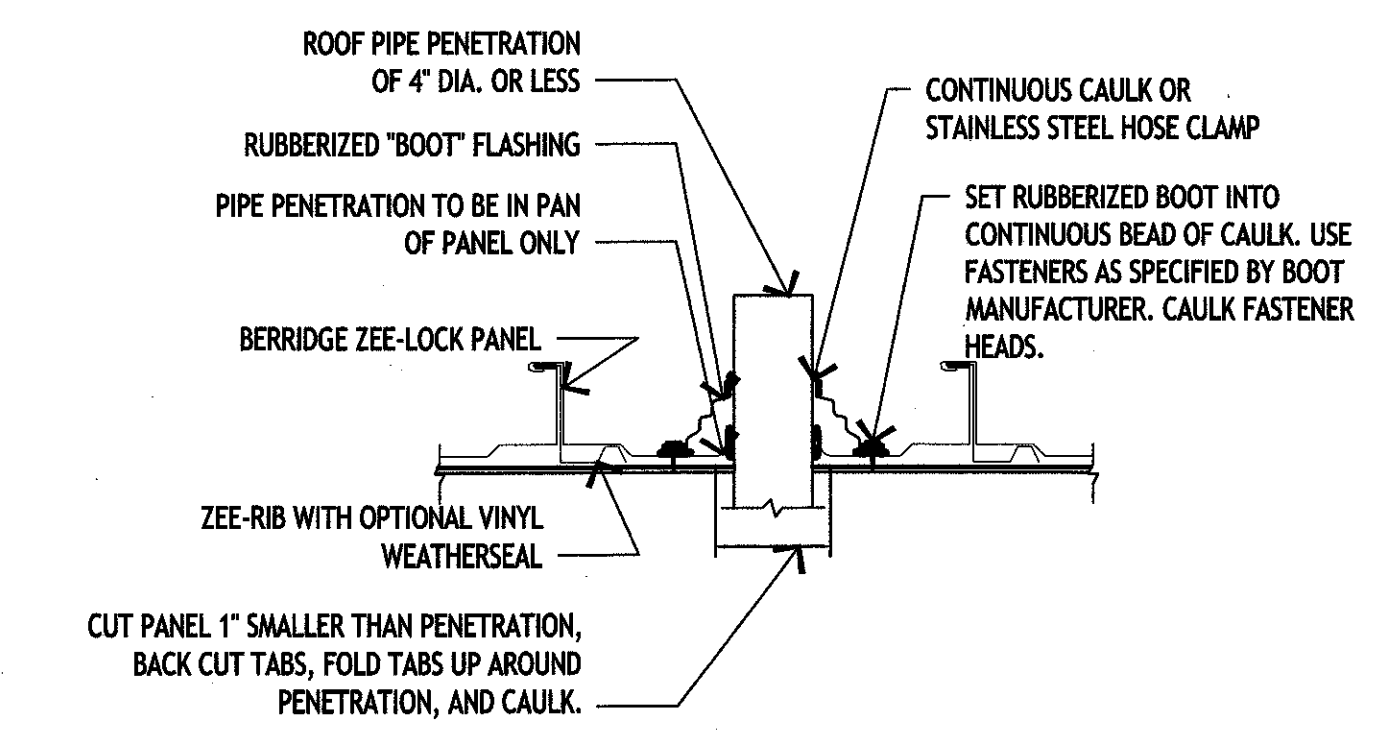

**A-9 ROOF PENETRATION DETAIL**  
3"-1'-0" @ VALLEY

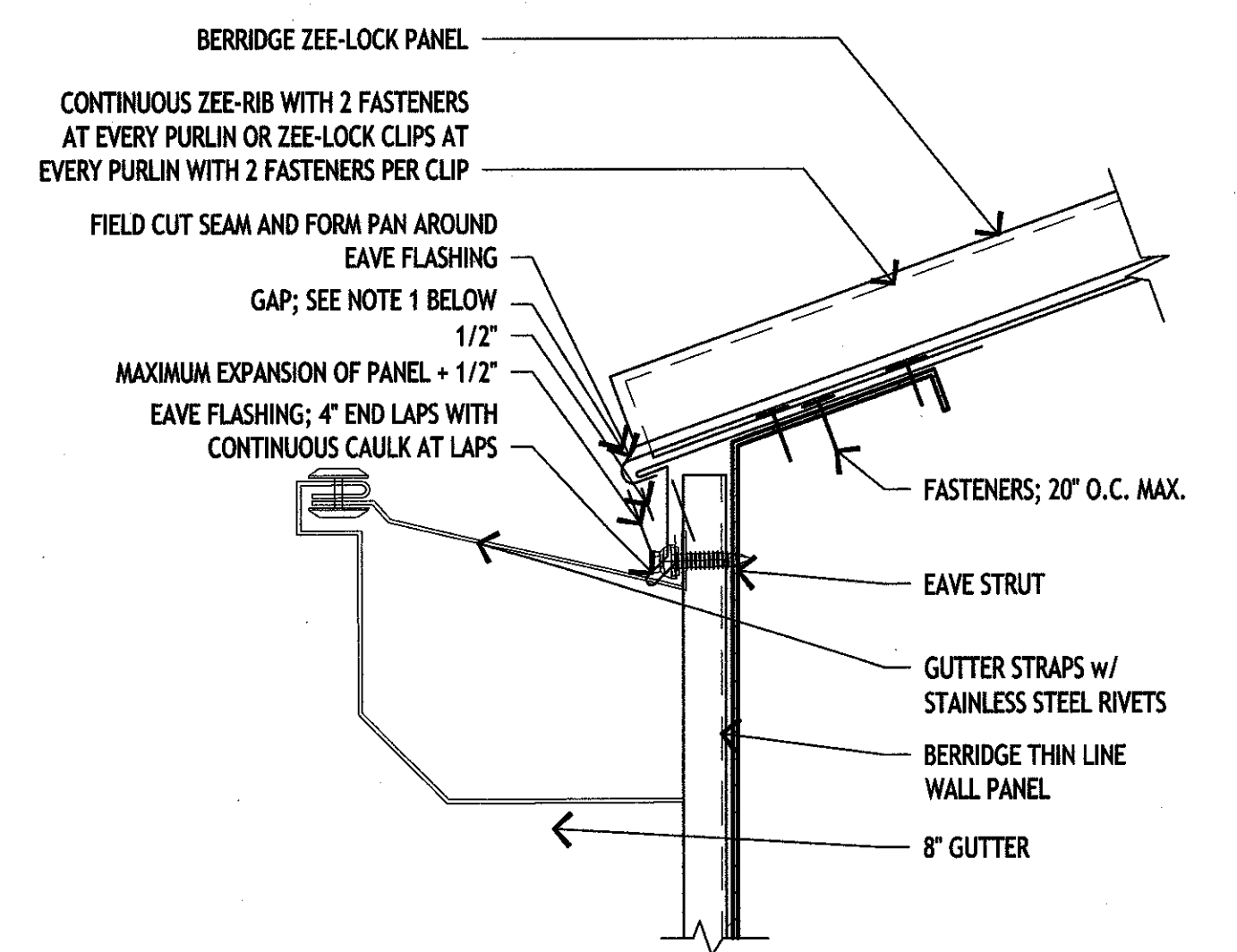

**A-13 EAVE DETAIL**  
3"-1'-0"

**MURRAY ARCHITECTS**  
131 Armond Center Court  
Baton Rouge, LA 70801  
(985) 755-7757  
fax (985) 725-0182

no.	revisions	date
1		
2		
3		
4		
5		
6		

**HARRY HURST MIDDLE SCHOOL WING ADDITION**  
170 Roadrunner Lane, Destrehan, Louisiana 70047  
ROOF DETAILS

MICHAEL TABS REG. NO. 8959  
MURRAY ARCHITECTS  
project number 1007  
date 6.14.2010  
phase CD  
drawing number **A.5.1**

ALL RIGHTS ARE RESERVED TO MURRAY ARCHITECTS. THESE DOCUMENTS ARE PROTECTED BY UNITED STATES COPYRIGHT LAW. THEY HAVE BEEN PREPARED SPECIFICALLY FOR THE PROJECT IDENTIFIED AND ARE NOT BE LOANED, REPRODUCED, COPIED, OR OTHERWISE USED IN ANY MANNER WITHOUT THE EXPRESS WRITTEN PERMISSION OF MURRAY ARCHITECTS. ALL RIGHTS ARE RESERVED TO MURRAY ARCHITECTS.