

SECTION 4
 1.17 THRU STAIRS
 1" = 1'-0"

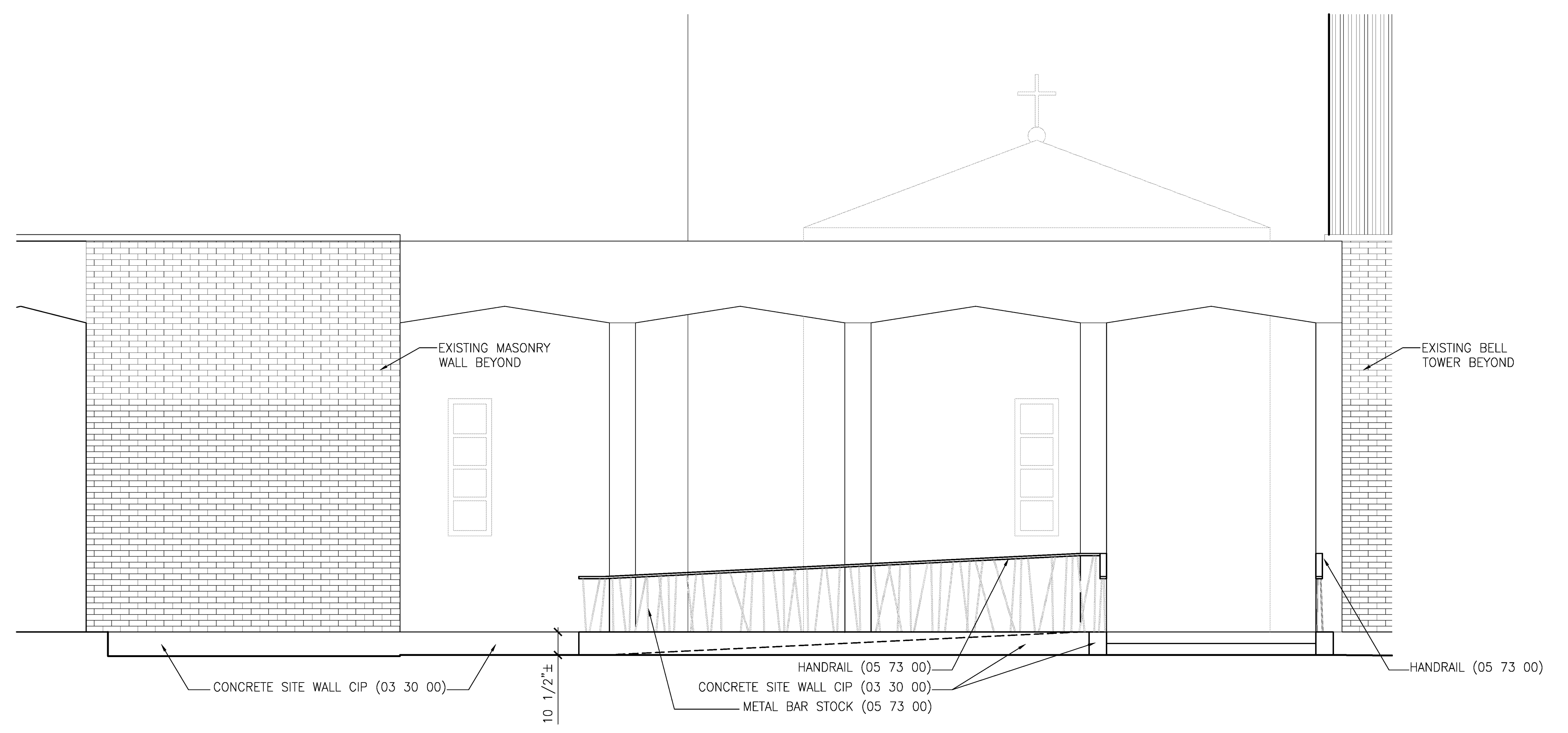

RAMP ELEVATION
 1.17 @ PRENTISS AVE.
 3/8" = 1'-0"

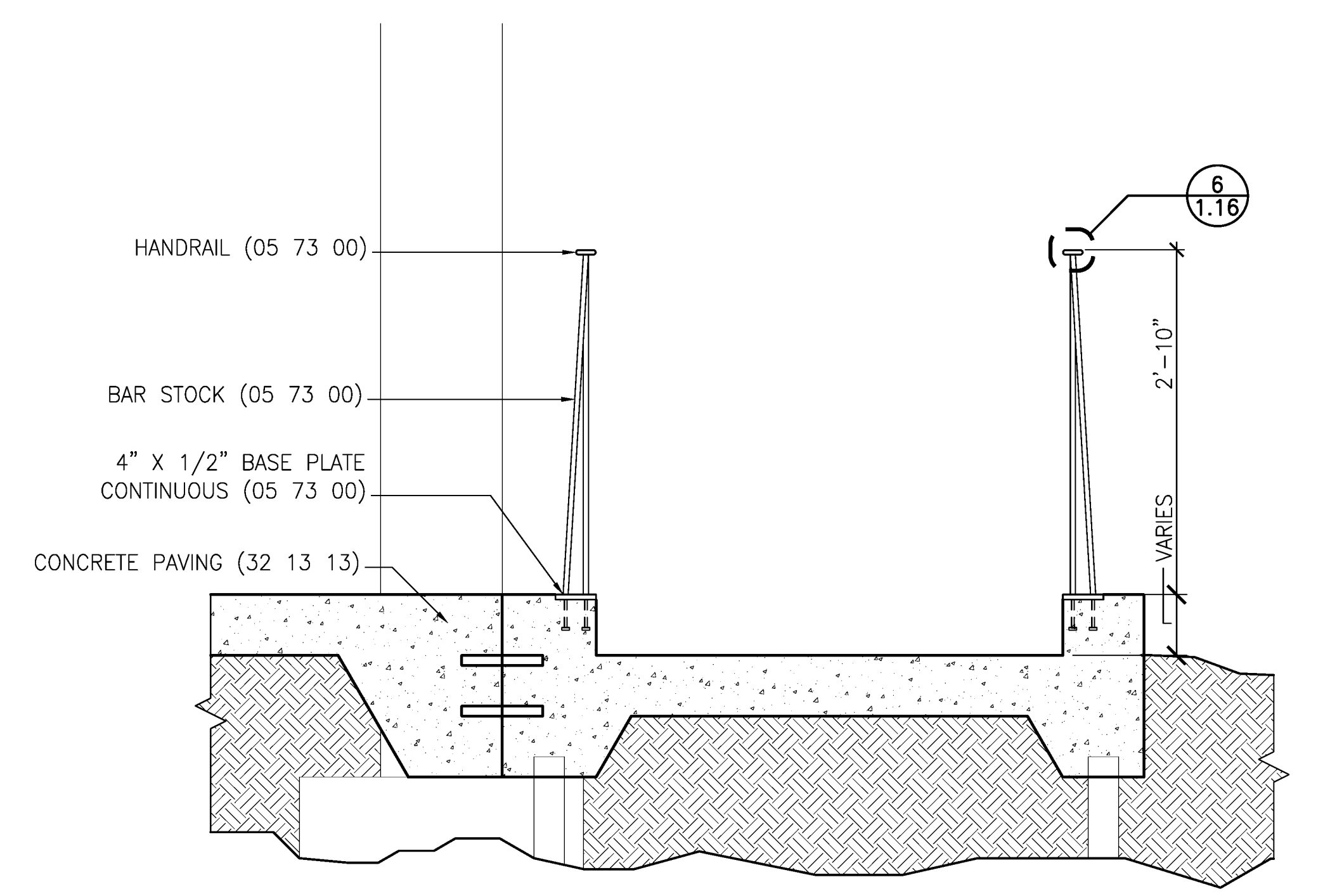

SECTION 3
 1.17 THRU RAMP
 1" = 1'-0"

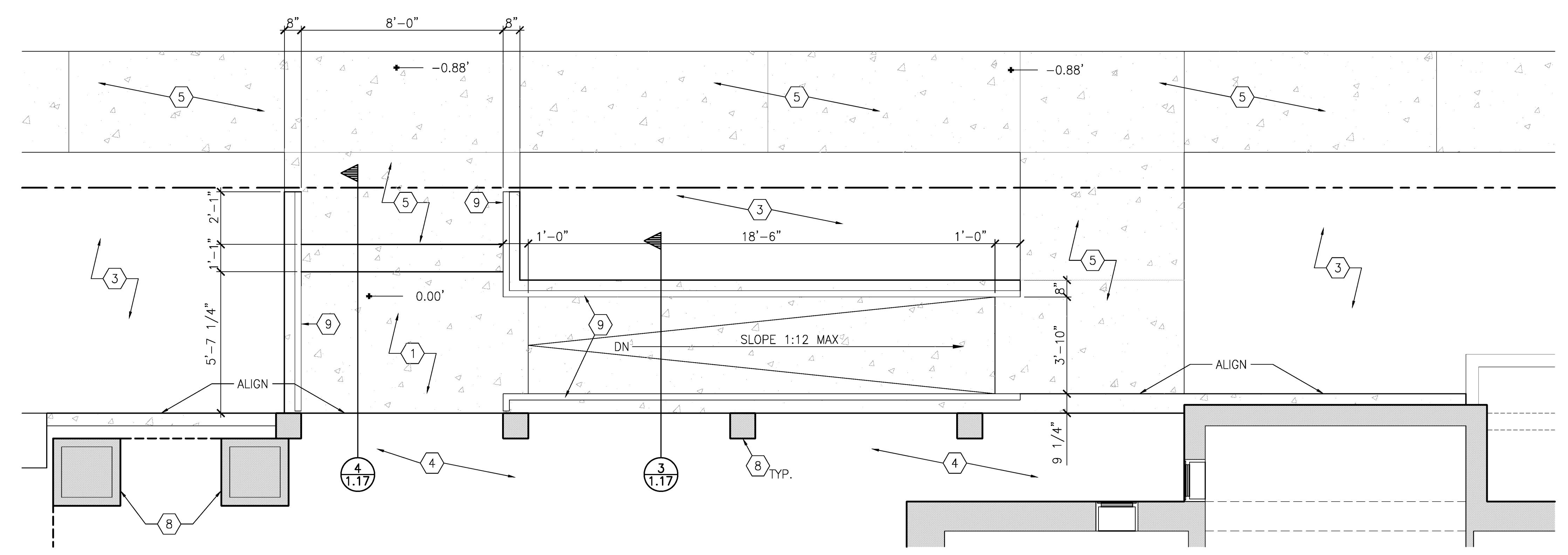

ENLARGED RAMP PLAN
 1.17 @ PRENTISS AVE.
 3/8" = 1'-0"

CLARIFICATION OF REFERENCE DESIGNATIONS	
1	PILE SUPPORTED CONCRETE PLAZA SLAB - REF STRUCTURAL
2	CONTROL JOINT - REF STRUCTURAL
3	LANDSCAPE AREA
4	PREP & COAT EXISTING CONCRETE CANOPY SLAB WITH TRAFFIC TOPPING (07 18 00)
5	CONCRETE WALK - REF CIVIL
6	NOT USED
7	PROTECT EXISTING TREES DURING CONSTRUCTION; MINIMIZE WORK AND VEHICULAR TRAFFIC BENEATH DRIP LINE
8	EXISTING COLUMNS TO REMAIN
9	HANDRAIL (05 73 00)

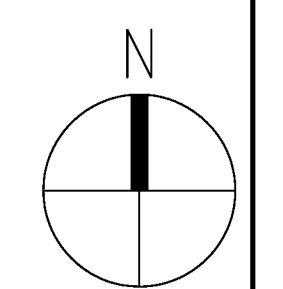

P:\2009_P\Projects\09007_T01L Church Drawings\01Site\0116_SiteDetails.dwg
 07 Jul 10 - 11:01am

Date: 7 JULY 2010

E+D+R No. 09007
 Drawn By: WEST

Drawing Title:
 SITE DETAILS

Sheet No: